

# Micky

Twin Spot Emergency Light with Self test



Self test function



RA>80



3YR WARRANTY

## FEATURES

- Low power consumption
- Wall mount
- Self testing function
- Non-maintained
- 3 hour discharge
- Designed and manufactured to AS/NZS2293.3
- Polycarbonate body
- Dali option available as special order

## DIMENSIONS

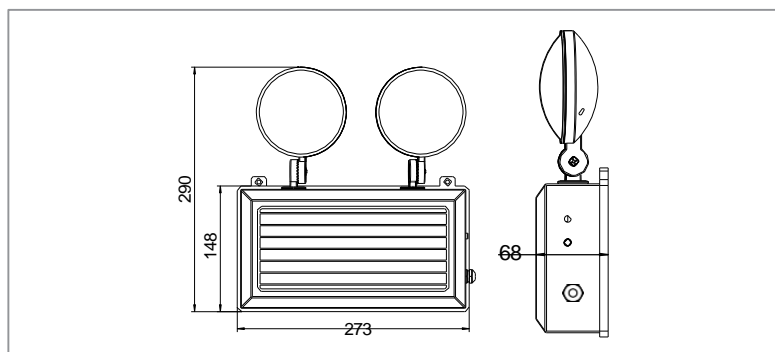

## SPECIFICATIONS

Order Code	E1709
Model Number	LWME2109
Input Voltage	240v
Wattage	2 x 3w
Construction	Polycarbonate body
Mounting	Wall mounting
Beam Angle	120°
Operating Mode	Non Maintained
Testing System	Self Testing
Battery	Lithium 3000mAh LiFePO4 3 hour discharge
AS2293 Classification	C0=D40 C90=D40
Applicable Standard	AS/NZS2293.3
Operating Temp	1°C to 40°C
Battery	3 hour discharge
Dimensions (mm)	290x273x68
Weight	0.92kg