

Jade

Recessed Blade Exit Light



FEATURES

- Low 3w standby power consumption
- Comes with both single and double sided decals in running man "Pictograph" and the "EXIT" decal
- Large terminal block & cable entry
- Polycarbonate body with transparent acrylic blade
- Maintained
- Manual test switch
- Cutout size - 430x75mm
- 2200mAh lithium battery technology
- Designed and manufactured to AS/NZS2293.3

DIMENSIONS

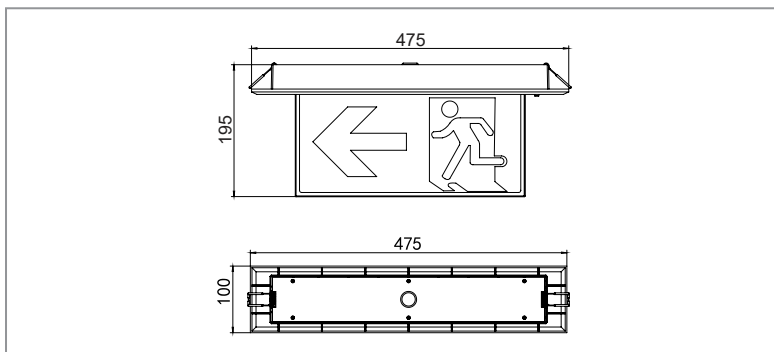

SPECIFICATIONS

Order Code	
- White	E1703
- Black	E1703B
Model Number	
- White	LWJE1703
- Black	LWJE1703B
Input Voltage	240v
Construction	Polycarbonate body with transparent acrylic blade
Mounting	Ceiling
Operating Mode	Maintained
Testing System	Manual
Battery	Lithium 2200mAh 3 hour discharge
Classification	C0: D12.5 C90: D8
Viewing Distance	24m
Applicable Standard	AS/NZS2293.3
Lamps	LED 50,000hrs
Operating Temp	1°C to 40°C
Dimensions (mm)	475x195x100
Weight	1.56kg