

Evoke

Ceiling Mount Exit Light



Emergency



SAA



FEATURES

- Low power consumption
- 50,000hr LED - energy efficient, long life
- Wall and ceiling mount
- Easy testing and maintenance
- Maintained
- 3 hour runtime in emergency mode
- 3 years warranty
- 2200mAh lithium battery technology
- Designed and manufactured to AS/NZS2293.3

DIMENSIONS

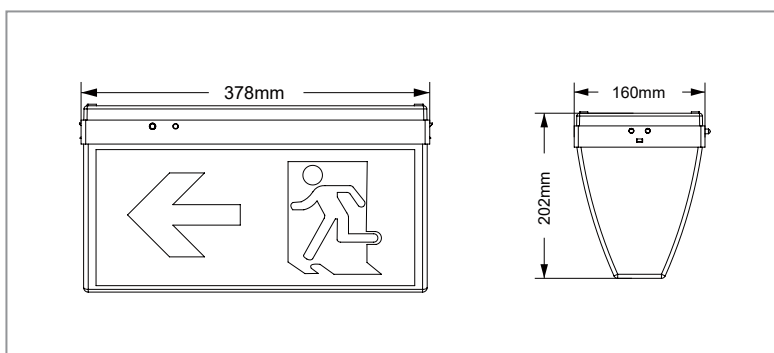

SPECIFICATIONS

Order Code	E1609
Model Number	LWNE1609
Input Voltage	240v
Construction	Polycarbonate
Mounting	Ceiling and wall
Operating Mode	Maintained
Testing System	Manual
Battery	Lithium 2200mAh 3 hour discharge
Classification	C0: D12.5 C90: D8
Viewing Distance	24m
Applicable Standard	AS/NZS2293.3
Lamps	LED 50,000hrs
Operating Temp	1°C to 40°C
Dimensions (mm)	378x202x160
Weight	1.56kg