

Battens

T8 LED Tube Weatherproof Emergency Batten



FEATURES

- Fitted with large terminal block allowing for fast installation and maintenance.
- Wide body to cover junction boxes and provides ample space for heat generating components.
- Constant current driver
- 3 hour discharge
- Polycarbonate base and tamper proof stainless steel clips
- 2 x 10w / 2 x 18w
- LED, 30,000hr life
- 1800mAh lithium battery technology
- Designed and manufactured to AS/NZS2293.3

DIMENSIONS

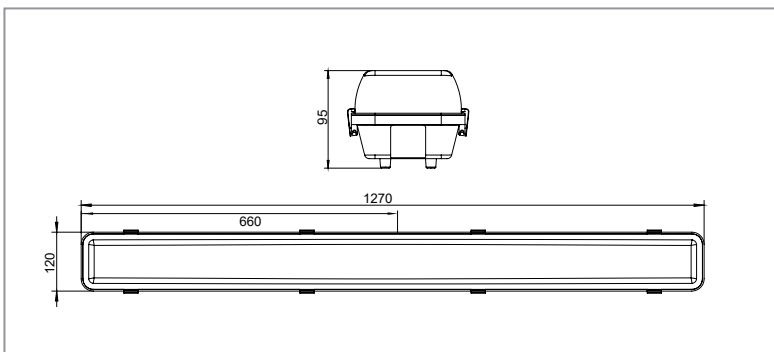

SPECIFICATIONS

	2ft	4ft
Order Code	B210WPE	B218WPE
Model Number	LWWB210E	LWWB218E
Input Voltage	240v	
Wattage	2 x 10w 6w (Emergency)	2 x 18w 6w (Emergency)
Lumen Output	2000lm	3600lm
Operating Mode	Sustained	
Classification	C0=D63 C90=D20	
Applicable Standard	AS/NZS2293.3	
Beam Angle	100°	
Construction	Polycarbonate body and diffuser. Stainless Steel clips and screws.	
Lamps	2 x T8 LED tubes 6000k 10w	2 x T8 LED tubes 6000k 18w
Terminal Block	12mm	
Dimming Options	No	
Dimensions (mm)	660x120x95	1270x120x65
Weight	2.5kg	5kg