

Batten

T8 Tube Batten - Weatherproof



FEATURES

- Battens feature quality components and superior finish to provide both good looks and reliability
- The batten range has been developed for applications such as basement car park, warehouses, fire stairs, commercial public spaces and industrial sites
- Fitted with large terminal block allowing fast installation and maintenance
- Wide body to cover junction boxes and provides ample space for heat generating components
- Replaceable T8 LED tubes
- Polycarbonate base and tamper proof stainless steel clips

DIMENSIONS

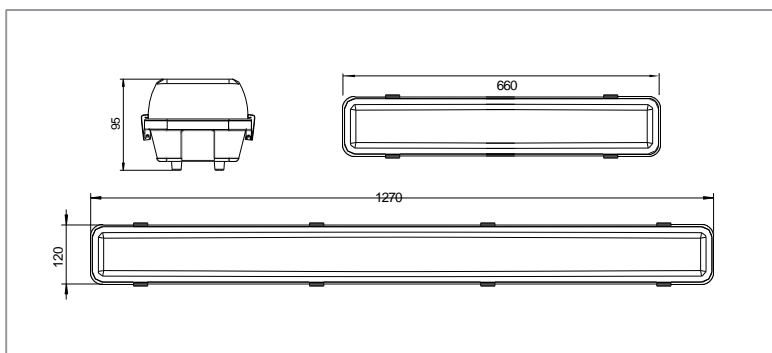

SPECIFICATIONS

	2ft	4ft
Order Code	B210WP	B218WP
Model Number	LWWB210	LWWB218
Input Voltage	240v	
Wattage	2 x 10w	2 x 18w
Lumen Output	2000lm	3600lm
Beam Angle	100°	
Construction	Polycarbonate body and diffuser. Stainless Steel clips and screws.	
Lamps	2 x T8 LED tubes 6000k 10w	2 x T8 LED tubes 6000k 18w
Terminal Block	12mm	
Dimming Options	No	
Dimensions (mm)	660x120x95	1270x120x65
Weight	1.9kg	3.8kg