

Battens

T8 LED Tube Prismatic Emergency Batten



FEATURES

- Battens feature quality components and superior finish to provide both good looks and reliability
- Developed for applications such as basement car parks, warehouses, fire stairs, commercial public spaces and industrial sites
- Low power consumption
- Wall & ceiling mount
- Easy testing and maintenance
- Sustained
- 1800mAh lithium battery technology
- Designed and manufactured to AS/NZS2293.3

DIMENSIONS

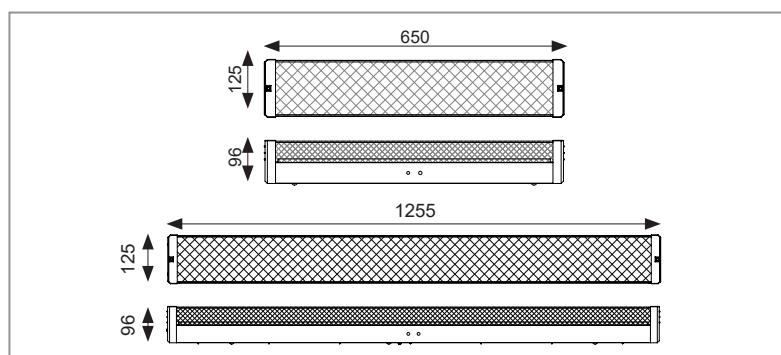

SPECIFICATIONS

	2ft	4ft
Order Code	B210PE	B218PE
Model Number	LWB210PE	LWB218PE
Input Voltage	240v	
Wattage	2 x 10w 2 x 3w (Emergency)	2 x 18w 2 x 3w (Emergency)
Lumen Output	2000lm	4000lm
Operating Mode	Sustained	
Beam Angle	100°	
Classification	C0=D50 C90=D20	
Applicable Standard	AS/NZS2293.3	
Construction	Powder coated steel body with polycarbonate lamp holders	
Lamps	2 x T8 LED tubes 6000k 10w	2 x T8 LED tubes 6000k 18w
Terminal Block	12mm	
Dimming Options	No	
Dimensions (mm)	650x125x96	1255x125x96
Weight	2.3kg	3.575kg