

# Battens

Tri-Colour Weatherproof Emergency Batten with Sensor Socket

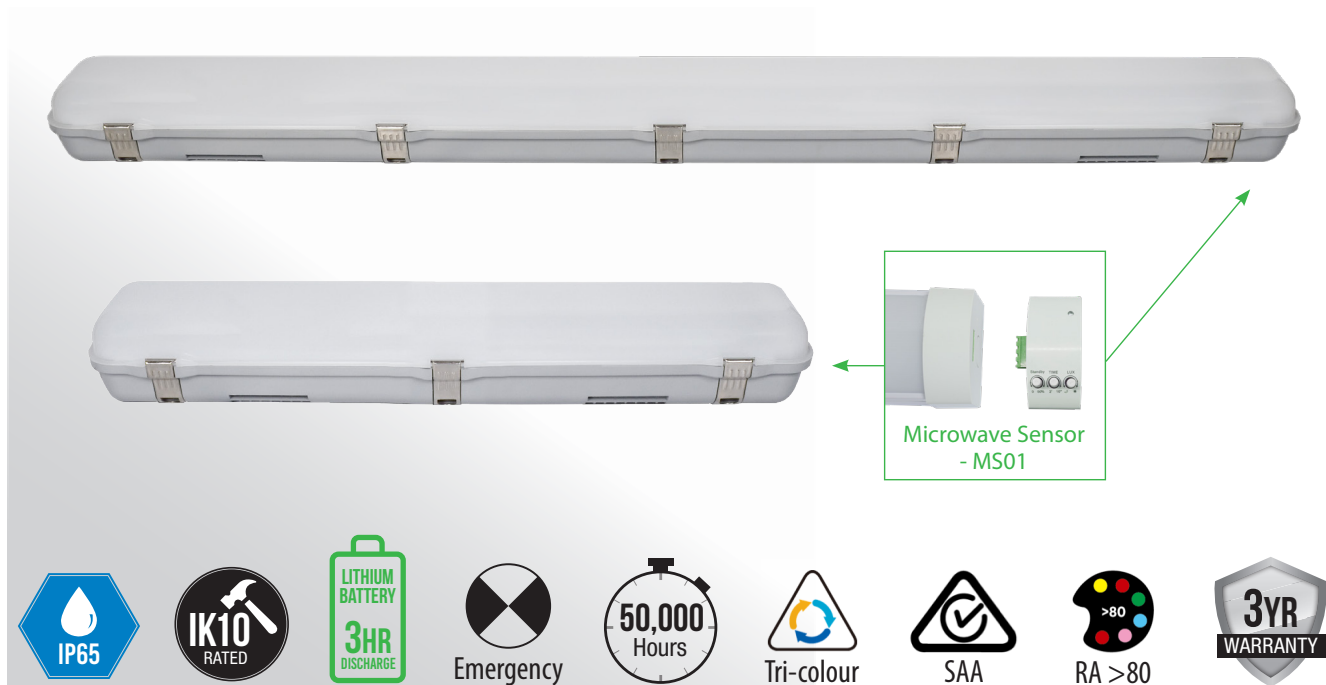

## FEATURES

- 20w/40w power selectable (4 foot only)
- Fitted with large terminal block allowing for fast installation and maintenance
- Wide body to cover junction boxes and provides ample space for heat generating components
- Tri-colour 3000k/4000k/5700k - switchable
- 30,000hr life, LED CCT panel
- Optional microwave sensor (MS01)
- Designed and manufactured to AS/NZS2293.3

## DIMENSIONS

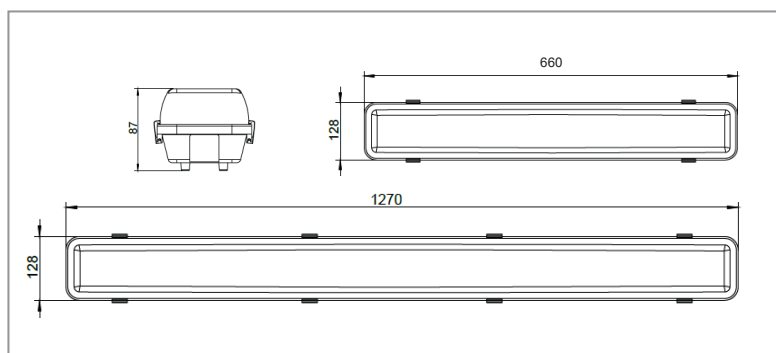

## SPECIFICATIONS

|                     | 2ft   | 4ft                                     |
|---------------------|---|---|
| Order Code          | B1903E  | B1902E                                  |
| Model No.           | LWWB1903-E  | LWWB1902-E                              |
| Input Voltage       | 240v  |   |
| Wattage             | 20w<br>6w (Emergency)   | 20w/40w<br>switchable<br>6w (Emergency) |
| Lumen Output        | 2000lm  | 4000lm                                  |
| Operating Mode      | Maintained  |   |
| Classification      | C0=D63 C90=D32  |   |
| Applicable Standard | AS/NZS2293.3  |   |
| Battery             | 1800mAh   |   |
| Beam Angle          | 100°  |   |
| Construction        | Polycarbonate body and diffuser.<br>Stainless Steel clips and screws. |   |
| Dimensions (mm)     | 660x128x87  | 1270x128x87                             |
| Weight              | 1.38kg  | 2.6kg                                   |